

P1 BLACK MACADAM (PEDESTRIAN)
0101 Scale 1:10. See NBS Q22.110A

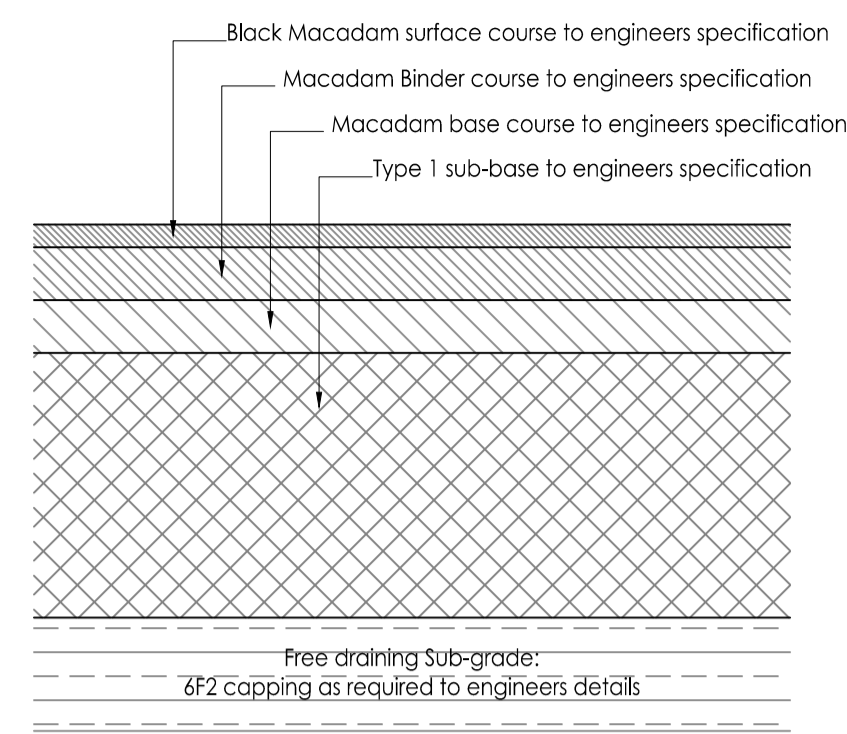

P1b BLACK MACADAM (VEHICULAR)
0101 Scale 1:10. See NBS Q22.107J

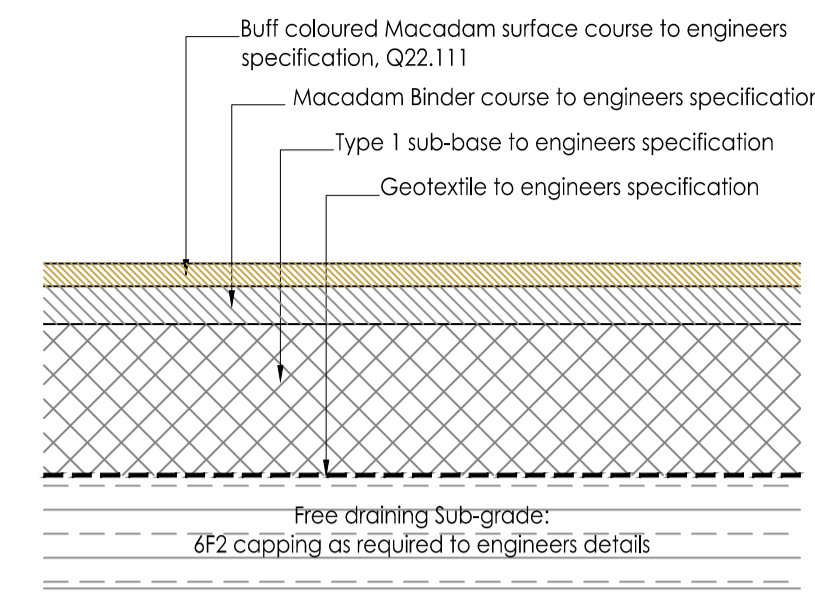

P2 BUFF MACADAM (PEDESTRIAN)
0101 Scale 1:10. See NBS Q22.111 (non permeable)

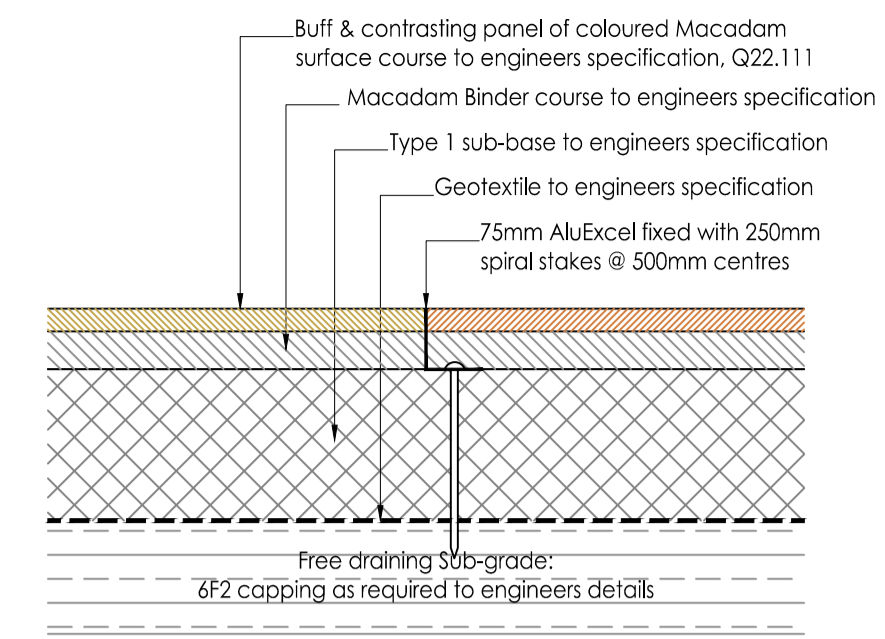

P2 BUFF & COLOURED MACADAM (PEDESTRIAN)
0101 Scale 1:10. See NBS Q22.111 (non permeable)

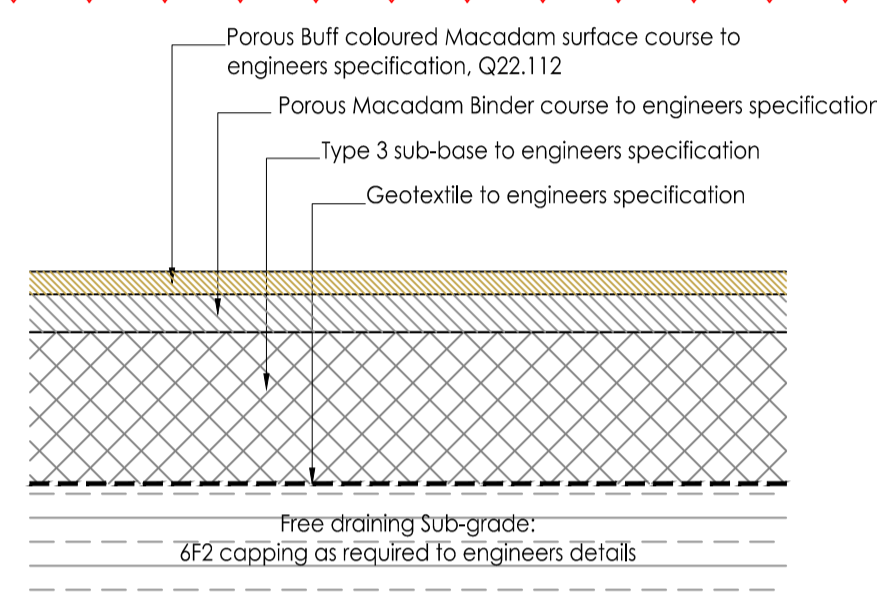

P2a BUFF MACADAM (COURTYARD)
0101 Scale 1:10. See NBS Q22.112 (Permeable to courtyard only)

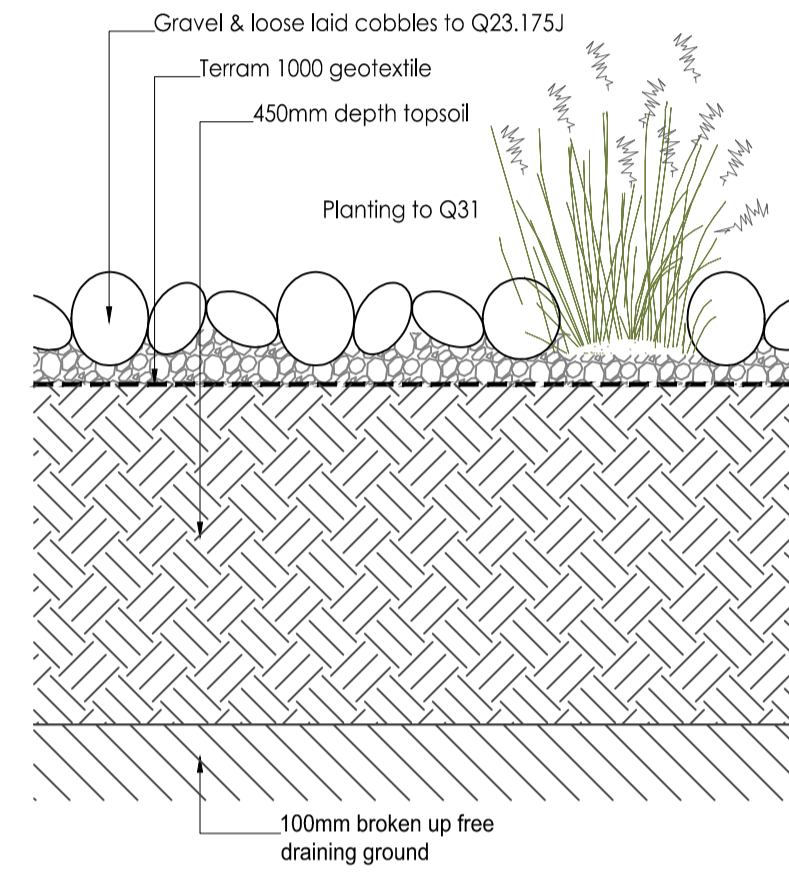

P3 COBBLES & BOULDERS
0101 Scale 1:10. See NBS Q23.175J

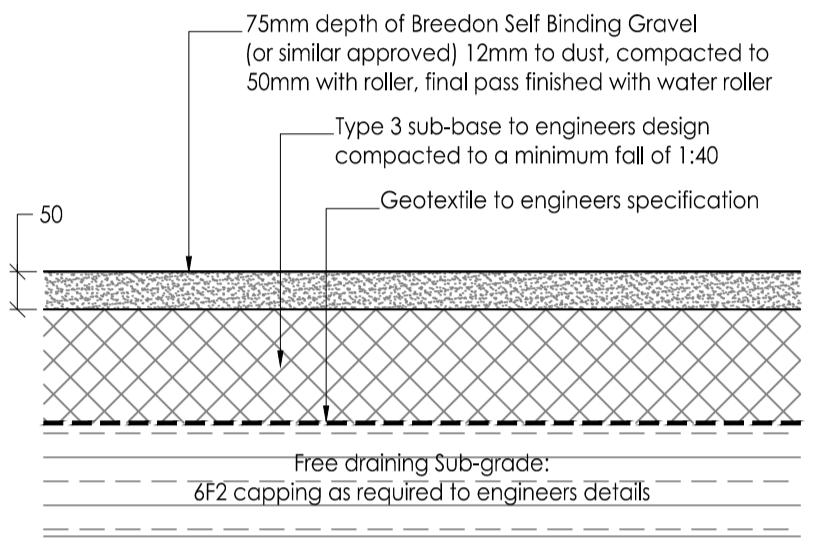

P4 SELF BINDING GRAVEL
0101 Scale 1:10. See NBS Q23.130J

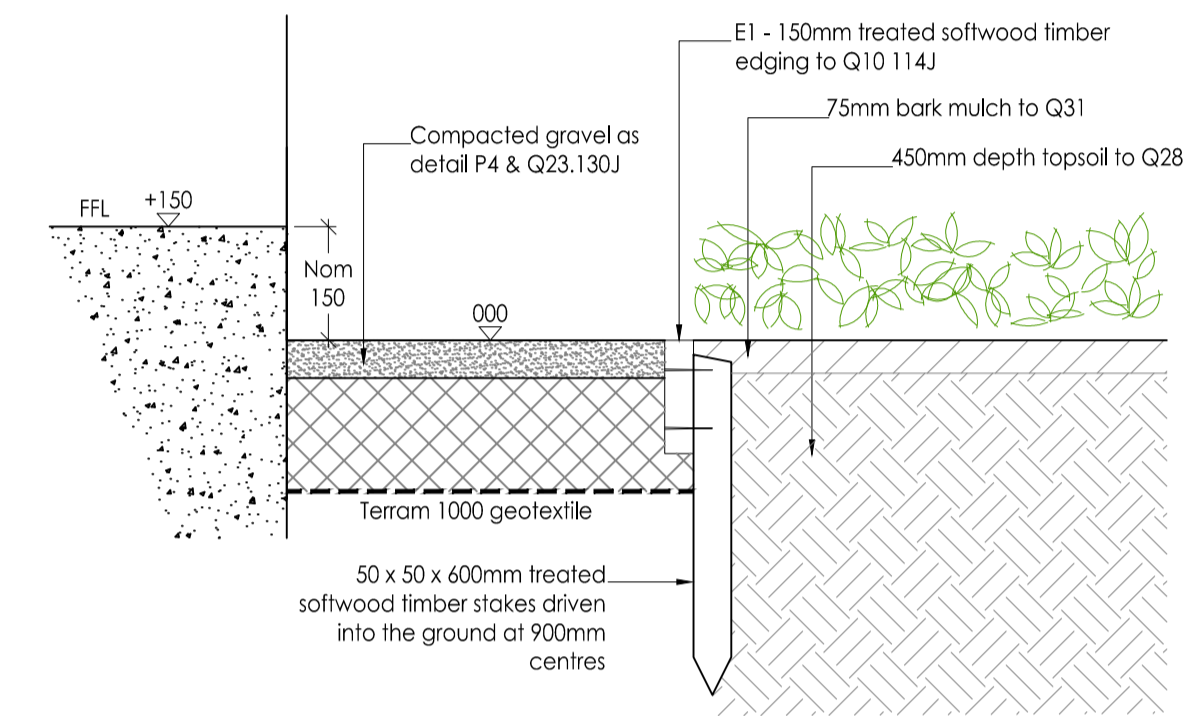

P4a SELF BINDING GRAVEL EDGE TO BUILDING
0101 Scale 1:10. See NBS Q23.130J

C02
New detail -
All paving in courtyard to be porous

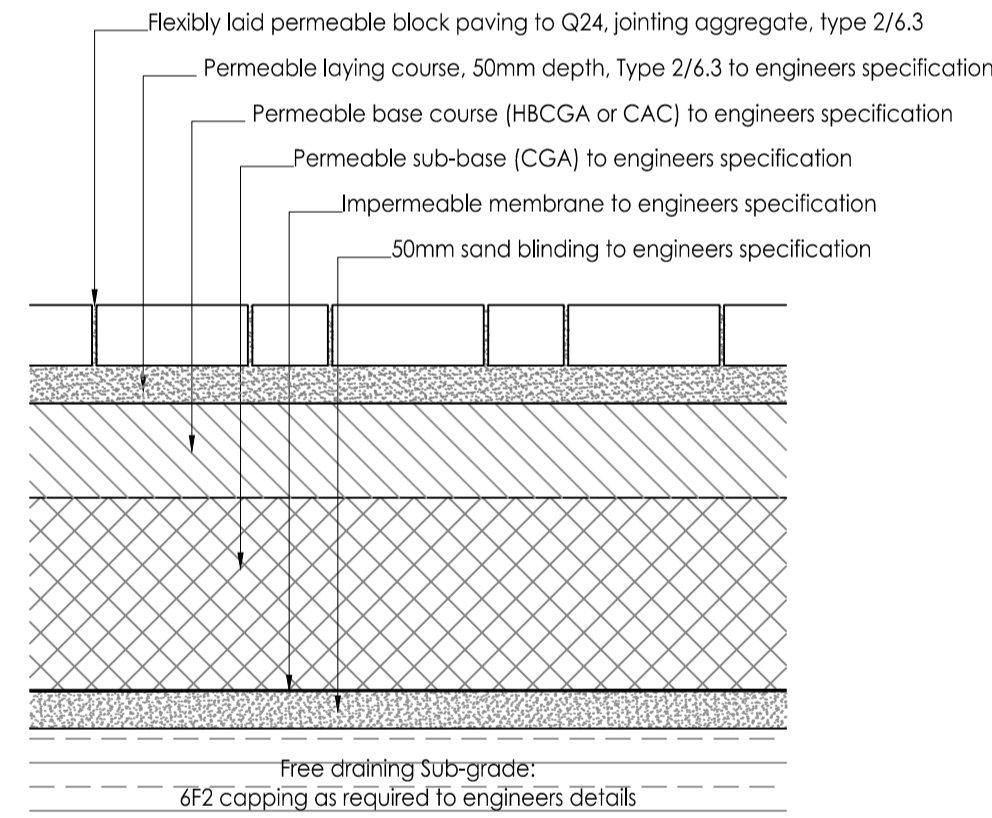

P06 PERMEABLE FLEXIBLE BLOCK PAVING (VEHICULAR)
0101 Scale 1:10. See NBS Q24.115

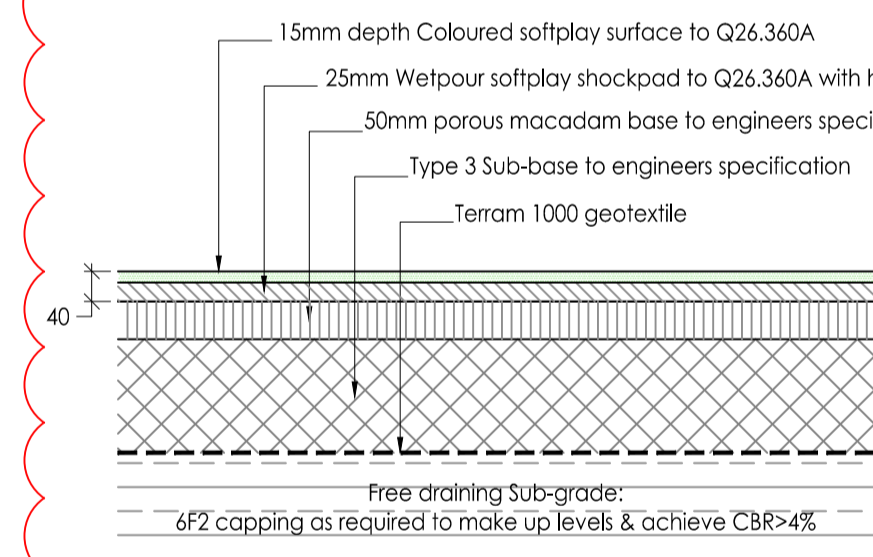

P11 PERMEABLE SOFT PLAY RUBBER SURFACING
0101 Scale 1:10. See NBS Q26.360A

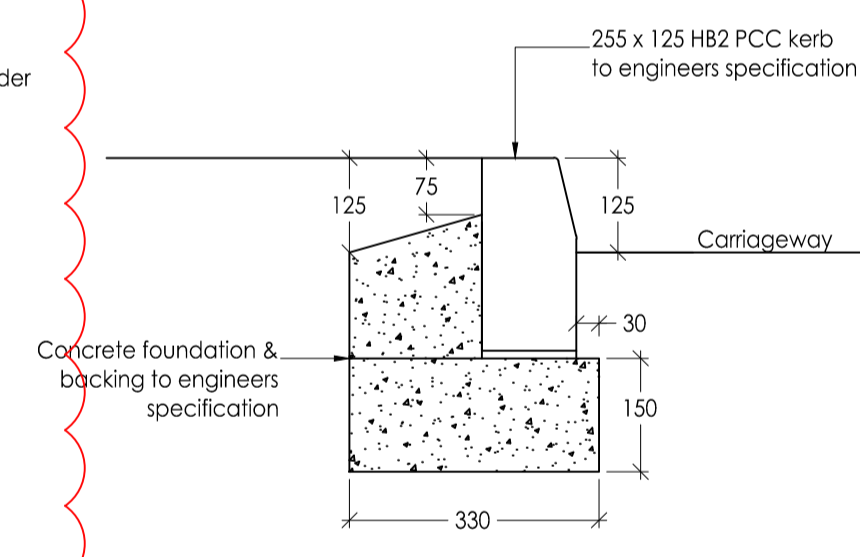

K1 PCC ROAD KERB
0101 Scale 1:10. See NBS Q10.110J

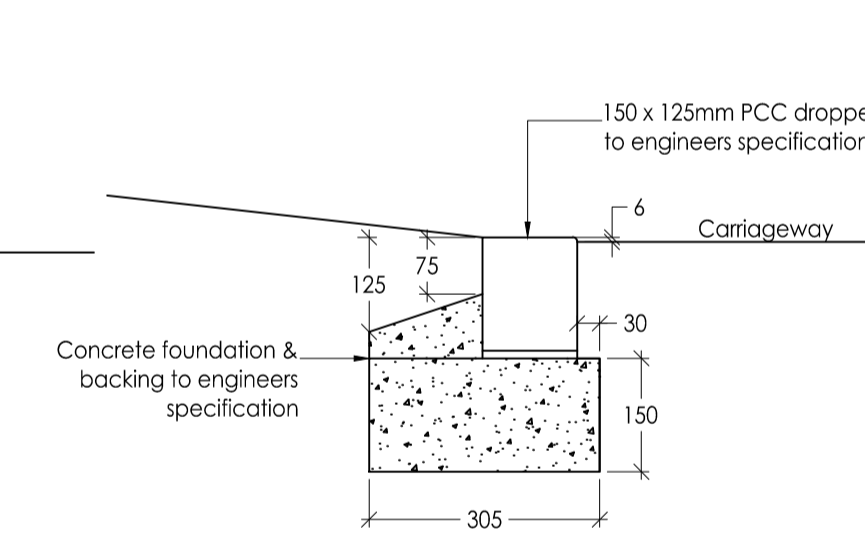

K3 PCC DROPPED ROAD KERB (6mm)
0101 Scale 1:10. See NBS Q10.110J

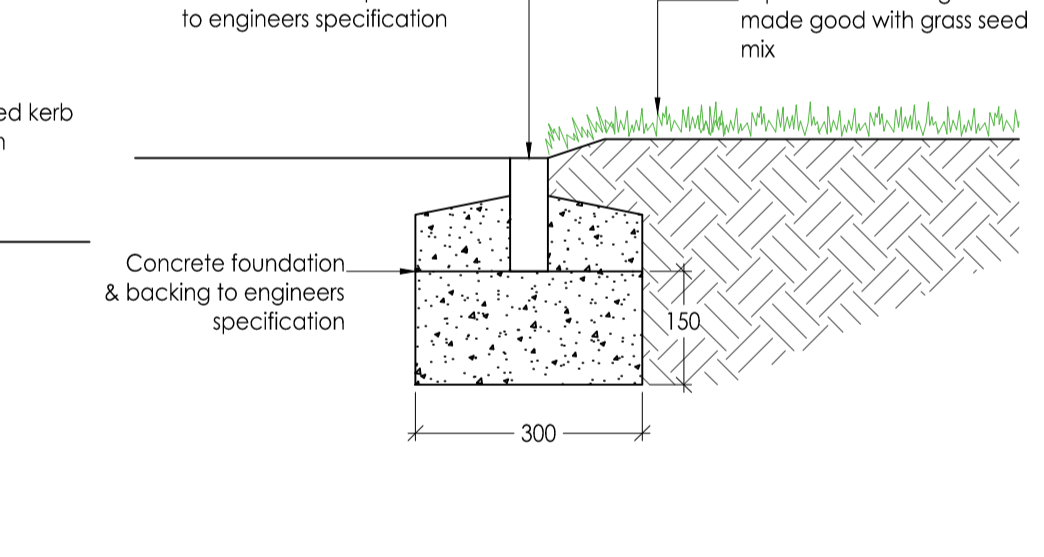

K4 PCC PIN KERB (Flush)
0101 Scale 1:10. See NBS Q10.112

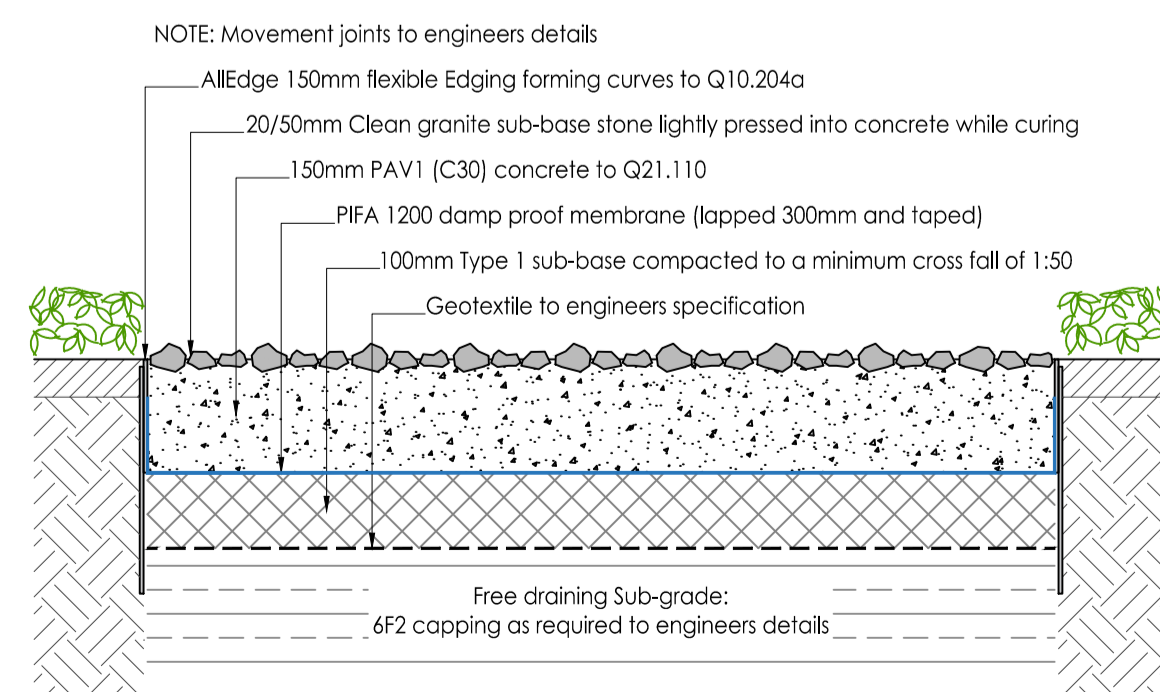

SP1 MIXED REHABILITATION CHALLENGE PAVING - GRAVEL
A Scale 1:10. See NBS Q25.165J

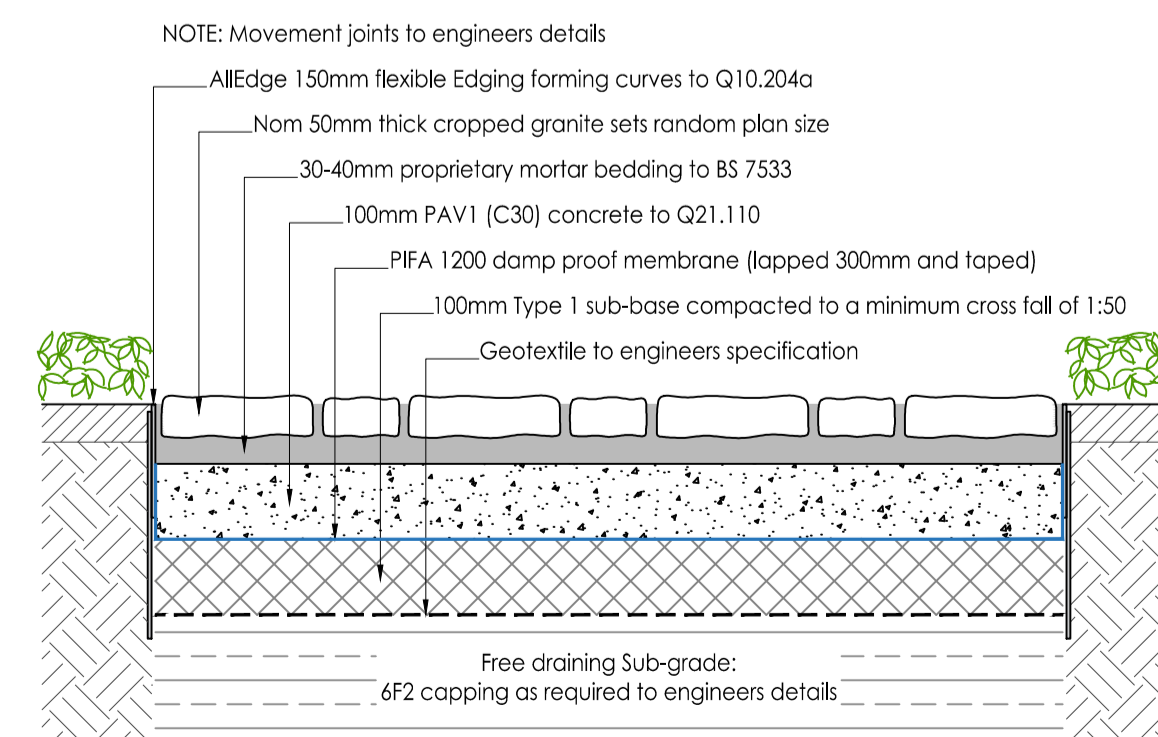

SP1 MIXED REHABILITATION CHALLENGE PAVING - CROPPED SETTS
B Scale 1:10. See NBS Q25.165J

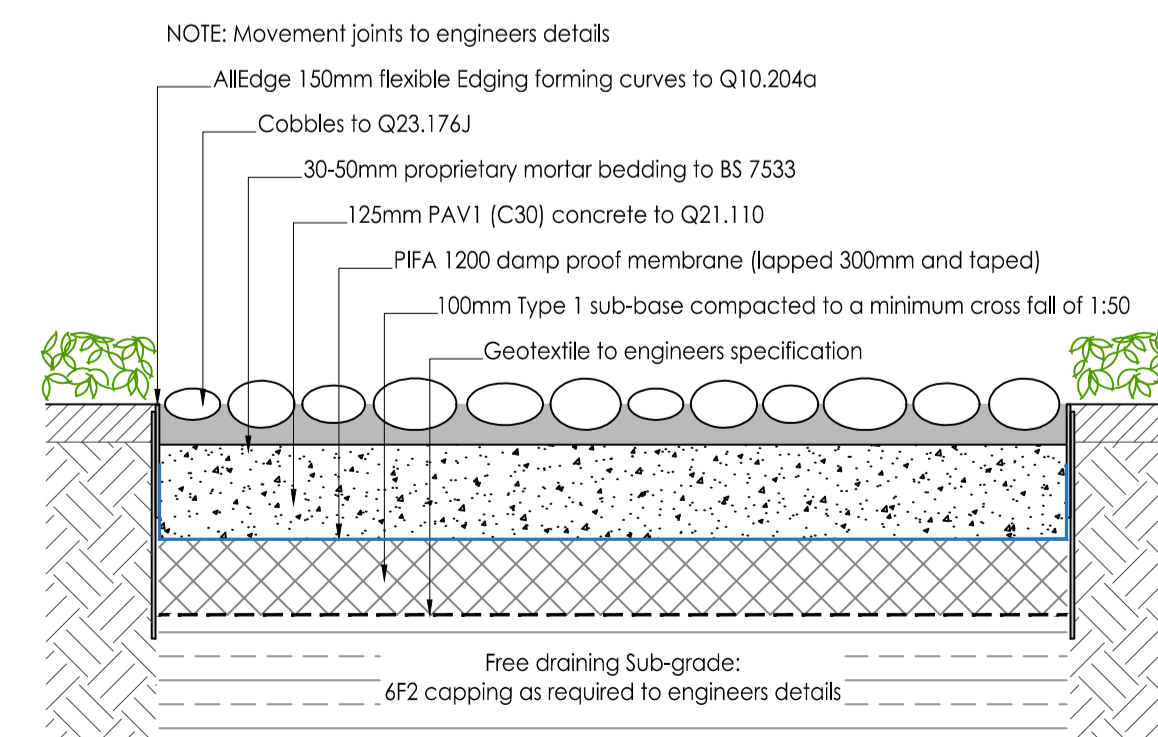

SP1 MIXED REHABILITATION CHALLENGE PAVING - COBBLES
C Scale 1:10. See NBS Q25.165J

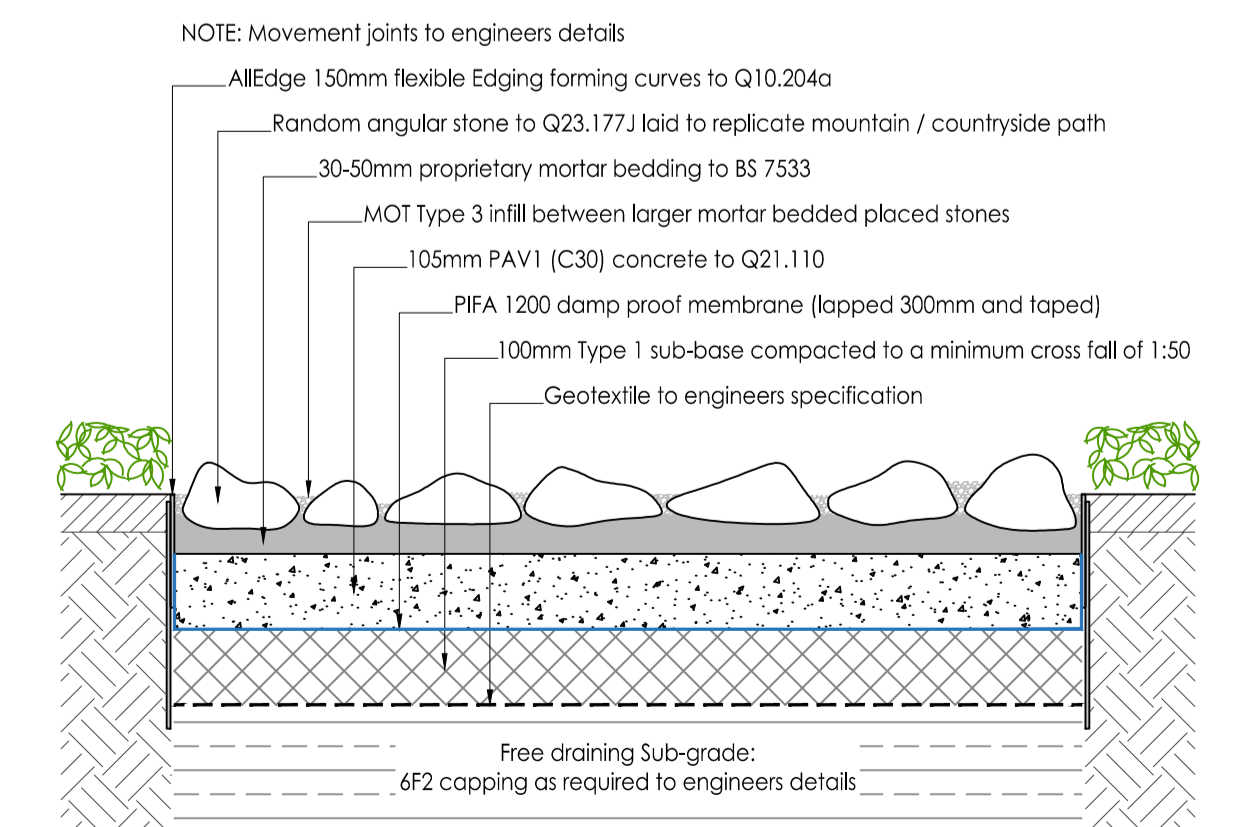

SP1 MIXED REHABILITATION CHALLENGE PAVING - ANGULAR STONE
D Scale 1:10. See NBS Q25.165J

NOTES:

DO NOT SCALE. Use figured dimensions only. The contractor is requested to check all dimensions before the work is put in hand. Copyright of this drawing belongs solely to Iteriad Ltd ©. This drawing must only be used for the purpose for which it is supplied and its contents must not be reproduced for any purpose without written permission. Areas indicated, or areas calculated from this drawing should be used for valuation purposes or as the basis for development contracts. Iteriad Ltd is a limited liability company registered in England and Wales. Number 7966573

NOTES:
To be read in conjunction with Engineers & Architects information

All paving in courtyard to be porous (except concrete path SP1)

REV	DETAILS	AP	AP	KH	05.07.22
C02	Updated for porous paving in courtyard	AP	AP	KH	05.07.22
C01	First issue for construction approval	AP	AP	KH	27.06.22

CLIENT
North Cumbria Integrated Care NHS Foundation Trust

MASTERPLANNERS/LANDSCAPE ARCHITECTS
(iteriad)
Studio
2 Cringwood Cottages,
Ecclefling,
Windermere,
Cumbria
LA23 1JG
T: (+44) 15394 43018
E: studio@iteriad.com
W: www.iteriad.com

PROJECT TITLE
West Cumberland Hospital Phase 2

DRAWING TITLE
GROUND FLOOR LEVEL Typical Construction Details Paving & Kerbing

SCALE
1:10@A1

PURPOSE
For Constuction Approval

STATUS
S4

JOB/DRAWING NUMBER
WCHPH2-ITR-00-XX-DR-L-0101

REVISION
C02