

100
0 10
Millimetres

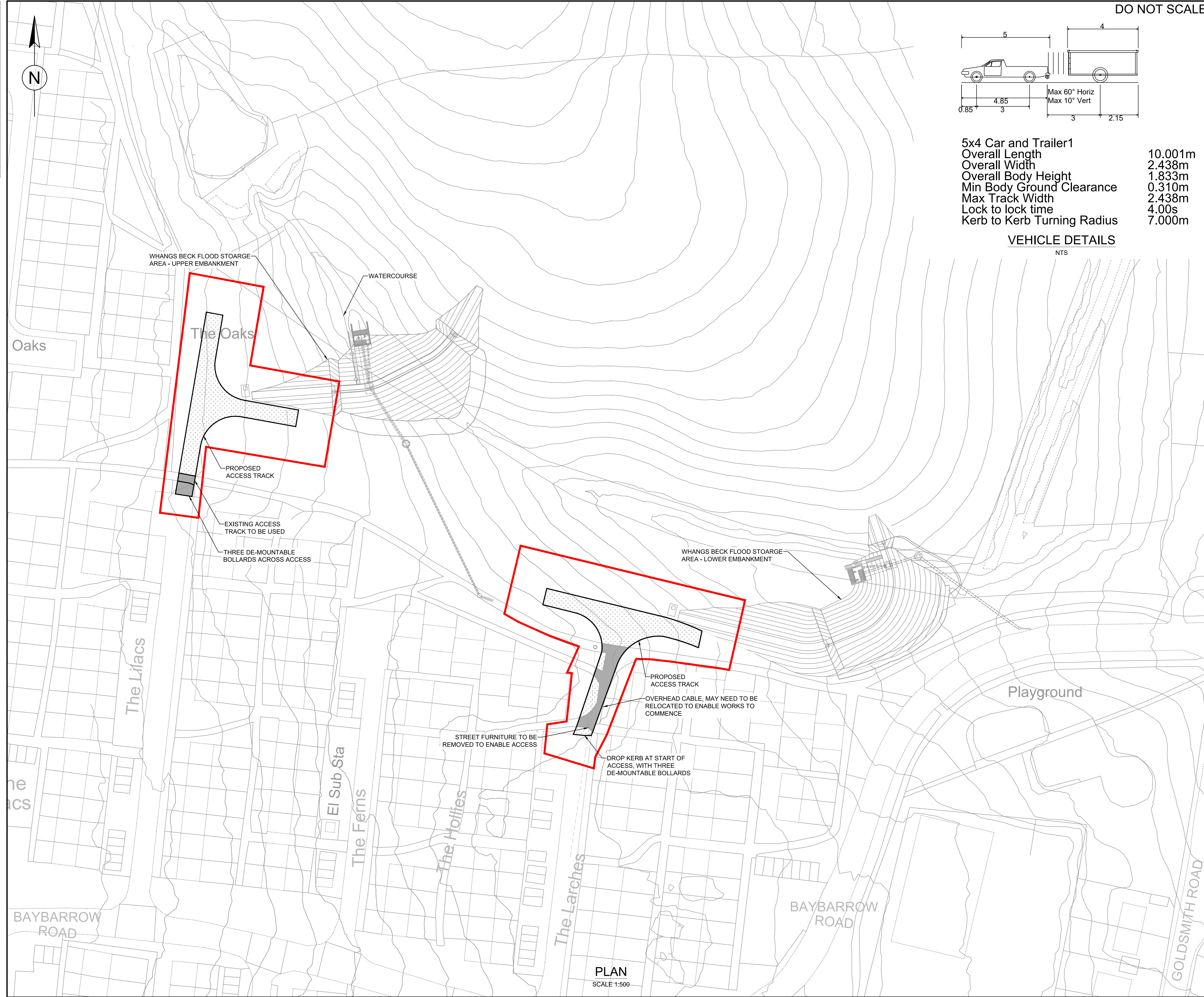

DO NOT SCALE

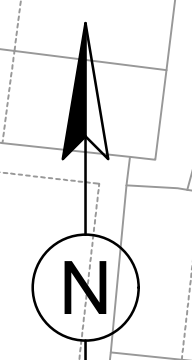
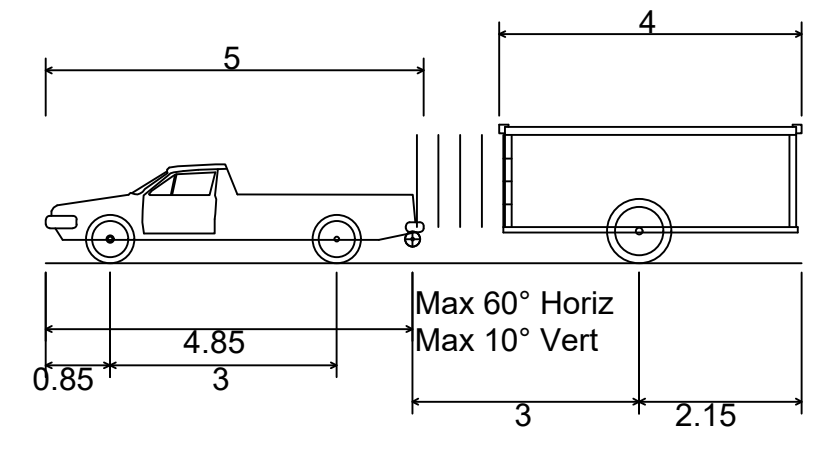

5x4 Car and Trailer1
 Overall Length 10.001m
 Overall Width 2.438m
 Overall Body Height 1.833m
 Min Body Ground Clearance 0.310m
 Max Track Width 2.438m
 Lock to lock time 4.00s
 Kerb to Kerb Turning Radius 7.000m

VEHICLE DETAILS

NTS

SAFETY, HEALTH AND ENVIRONMENTAL INFORMATION

In addition to the hazards/risks normally associated with the types of work detailed on this drawing, note the following:

- CONSTRUCTION
WORK WITHIN AND AROUND HIGHWAYS
INTERACTION WITH PUBLIC AND CLOSURE OF FOOTPATHS
- MAINTENANCE/CLEANING
N/A
- DECOMMISSIONING/DEMOLITION
N/A

It is assumed that all works will be carried out by a competent contractor working, where appropriate, to an approved method statement

- NOTES
- ALL DIMENSIONS ARE IN mm UNLESS OTHERWISE STATED.
 - ALL LEVELS ARE IN m AOD UNLESS OTHERWISE STATED.
 - ALL LEVELS SHALL BE CONFIRMED ON SITE.
 - ALL DETAILS SHOWN ON THIS DRAWING (INCLUDING LEVELS AND DIMENSIONS) ARE OUTLINE ONLY AND MAY BE SUBJECT TO CHANGE AS THE DESIGN DEVELOPS.
 - ASSUME THAT ALL WORKING AREAS WILL REQUIRE TOPSOIL STRIP PRIOR TO CONSTRUCTION WORKS.

- KEY
- TARMAC SURFACE FOOTWAY
 - GRASSCRETE
 - RED LINE BOUNDARY

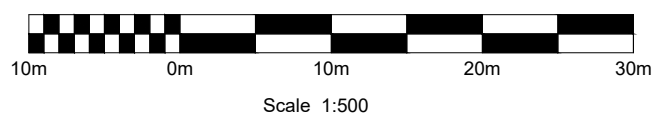

P01	11/11/20	FIRST ISSUE	GB	DSS	DSS
P02	12/11/20	FIRST ISSUE	CH	DSS	MWH
C01	08/12/20	UPDATED WITH CONTRACTOR COMMENTS	ST	DSS	SB
C02	20/04/22	FOR PLANNING APPROVAL	SN	CH	SB
Rev.	Date	Description	By	Chk'd	App'd

Drawing Status: **APPROVED - PUBLISHED** Suitability: **A1**

VBA Joint Venture Limited
 Chadwick House
 Birchwood Park
 Warrington
 WA3 6AE
 Tel: +44 (0)1925 238000
 Fax: +44 (0)1925 238500
 Copyright © VBA Joint Venture Limited (2018)



Project Title: **SKIRTING AND WHANGS BECK FRMS 5166264**

Drawing Title: **WHANGS BECK RESERVOIRS NEW ACCESS TRACKS GENERAL ARRANGEMENT**

Scale	Drawn	Checked	Reviewed	Authorised
AS SHOWN	SN	CH	SB	MK
Original Size	Date	Date	Date	Date
A1	08/03/22	09/03/22	16/03/22	20/04/22

Drawing Number: **IMNW000818-VBA-HA-3T3-DR-C-0001** Revision: **C02**

PLAN
SCALE 1:500