

General Notes

- This drawing should not be scaled for setting out purposes.
- This drawing shows the provisional design only and is subject to Local Authority approval.
- This drawing is based upon a topographical / ordnance survey provided by others.

Section A - A

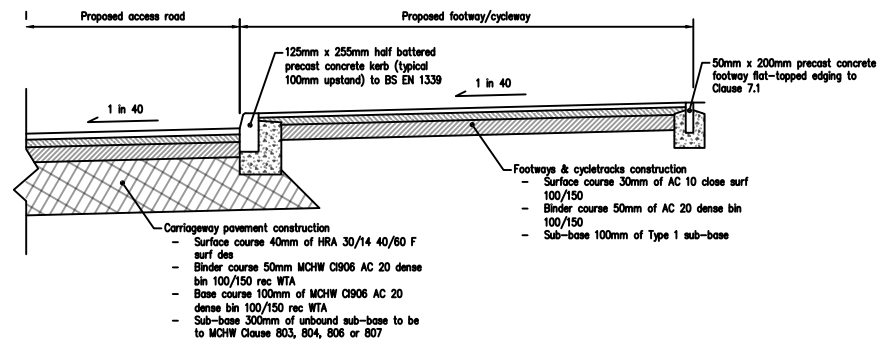

Section B - B

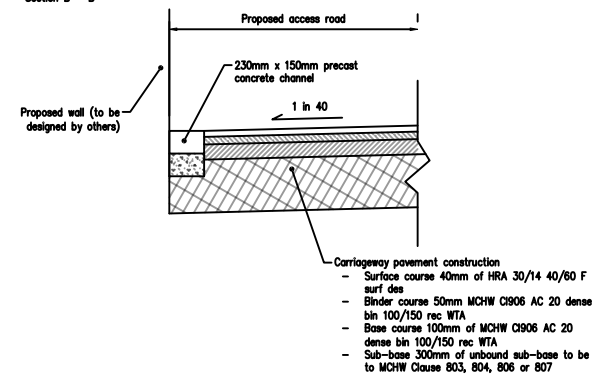

Section C - C

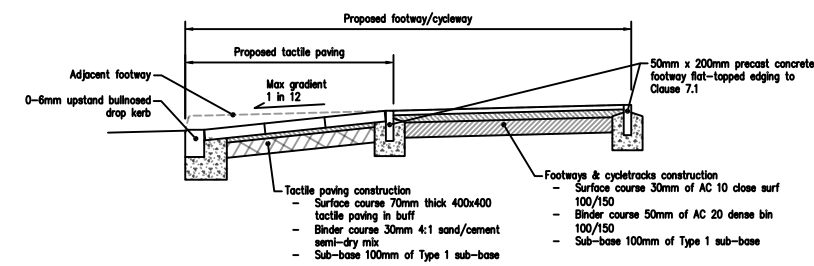

Section D - D

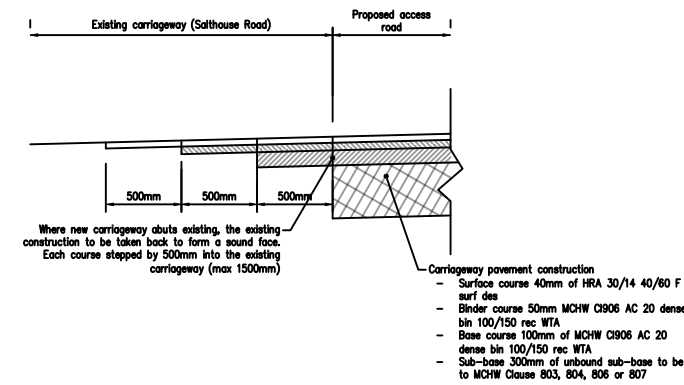

PROJECT TITLE
MILLIOM LEISURE CENTRE

DRAWING TITLE
TYPICAL SECTIONS

ORIGINATOR	PROJECT	VOL.	TYPE	ROLE	NUMBER
PRGN	2419	HGN	DR	CH	0004

CLIENT
FURNESS PARTNERSHIP

SCALE	SIZE	DRAWN	CHECKED	AUTHORISED	DATE
NTS	A3	AH	LO	AH	MAY 25

PARAGON HIGHWAYS
PEACH HOUSE WEST, THE WALLED GARDEN
NOSTELL ESTATE YARD
WAKEFIELD WF4 1AB

01924 291536
MAIL@PARAGONHIGHWAYS.COM